

MAXIM

MAX7432 Evaluation Kit

General Description

The MAX7432 evaluation kit (EV kit) is an assembled and tested circuit board that demonstrates the MAX7428, MAX7430, and MAX7432 standard definition video reconstruction filters and buffers. Windows® 98/2000 software provides a handy-user interface to exercise the features of the MAX7428/MAX7430/MAX7432.

Order the complete EV system (MAX7432EVC16) for comprehensive evaluation of the MAX7428/MAX7430/MAX7432 using a personal computer. Order the EV kit (MAX7432EVKIT) if the 68HC16MODULE module has already been purchased with a previous Maxim EV system, or for custom use in other μ C-based systems.

Windows is a registered trademark of Microsoft Corp.

MAX7432EVC16 Parts List

QTY	PART
1	MAX7432EVKIT
1	68HC16MODULE-DIP

Features

- ◆ Proven PC Board Layout
- ◆ Convenient On-Board Test Points
- ◆ Fully Assembled and Tested

Ordering Information

PART	TEMP RANGE	INTERFACE TYPE
MAX7432EVKIT	0°C to +70°C	User-Supplied
MAX7432EVC16	0°C to +70°C	Windows Software

Component Supplier

SUPPLIER	PHONE	FAX	WEBSITE
Sanyo USA	619-661-6835	619-661-1055	www.sanyo.com

Note: When contacting, please specify that you are using the MAX7428/MAX7430/MAX7432.

Component List

REFERENCE	QTY	DESCRIPTION
C1, C4–C18	16	0.1 μ F, 10V X7R ceramic capacitors (0805)
C2	1	0.01 μ F, 10V X7R ceramic capacitor (0805)
C3	1	1000pF, 10V X7R ceramic capacitor (0805)
C19–C24	6	220 μ F, 6V aluminum electrolytic capacitors (8 x 10.5), Sanyo 6CV220EX
C25	1	10 μ F, 10V tantalum capacitor (B)
C26–C31	6	Open (reserved for Sanyo 4CV820EX)
FB1, FB2	2	Ferrite beads (0805) Murata BLM21A102S
INA1–INA6, INB1–INB6, OUT1–OUT6	18	BNC female jacks, 4 pin, 0.250in. spacing
J1	1	2 x 20 right-angle socket
JU1	1	2-pin header
R1, R2, R3	3	301k Ω \pm 1% surface-mount resistors (1206)
R4	1	10k Ω \pm 5% surface-mount resistor (1206)

REFERENCE	QTY	DESCRIPTION
R5–R10	6	75 Ω \pm 1% surface-mount resistors (1206)
R11–R22	12	1M Ω \pm 5% surface-mount resistors (1206)
R23–R34	0	Open (reserved for 75 Ω \pm 5% surface-mount resistors)
TB1	1	0.200in. screw terminal block
U1	1	Maxim MAX7428EKA
U2	1	Maxim MAX7430EUB
U3	1	Maxim MAX7432EUD
None	1	PC board, MAX7432 EV kit
None	1	3 1/2in. software disk, MAX7432 EV kit
None	1	MAX7428 data sheet
None	1	MAX7430 data sheet
None	1	MAX7432 data sheet
None	1	MAX7432 EV kit data sheet
None	1	68HC16MODULE-DIP data sheet

MAX7432 Evaluation Kit

Quick Start

Recommended Equipment

Before you begin, you will need the following equipment:

- Maxim MAX7432EVKIT and 68HC16MODULE interface board
 - A small DC power supply, such as a 12V DC 0.5A plug-in transformer, or a 9V battery
 - A computer running Windows 98/2000
 - A spare serial communications port, preferably a 9-pin plug
 - A serial cable to connect the computer's serial port to the 68HC16MODULE
- 1) With the power off, connect a 7V to 20V DC power supply to the μ C module at the terminal block located next to the on/off switch, along the top edge of the μ C module. Observe the polarity marked on the board.
 - 2) Carefully connect the boards by aligning the 40-pin header of the MAX7432 EV kit with the 40-pin connector of the 68HC16MODULE-DIP module. Gently press them together. The two boards should be flush against one another.
 - 3) Connect a cable from the computer's serial port to the μ C module. If using a 9-pin serial port, use a straight-through, 9-pin female-to-male cable. If the only available serial port uses a 25-pin connector, a standard 25-pin to 9-pin adapter will be required. The EV kit software checks the modem status lines (CTS, DSR, DCD) to confirm that the correct port has been selected.
 - 4) Install the EV system software on your computer by running the INSTALL.EXE program on the floppy disk. The program files are copied and icons are created for them in the Windows Start Menu.
 - 5) Ensure that JU1 is closed (Table 1).
 - 6) Turn on the power supply.
 - 7) Start the program by opening its icon in the Start Menu. The program prompts you to connect the μ C module and turn its power on. Slide SW1 to the ON position. Select the correct serial port, and click OK. The program will automatically load code into the module.
 - 8) Click on Initialize MAX7432EVKIT to initialize the three devices on the MAX7432EVKIT board.
 - 9) Connect video signal sources to video inputs INA1–INA6 and INB1–INB6.
 - 10) Connect video displays to OUT1 through OUT3.

- 11) To verify the setup, switch all devices from input A to input B by selecting Input B in the Control Word and then clicking Broadcast.

Detailed Description of Software

Selecting the Device Address

At power-on reset, all devices are assigned address 0000. To assign unique addresses, each device must be initialized, starting with the device with the largest CEXT value. Clicking Initialize All Devices automatically assigns addresses from the Unused IDs list. Manually assign addresses by dragging the desired address from the Unused IDs list into the address assignment grid.

To reassign a chip's address, the chip must be reset. The Reset Chip button resets only the selected chip, while Reset All Chips broadcasts the reset command to all chips.

The EV kit is built with standard 20% capacitors, limiting the number of device addresses to seven. Applications requiring more than seven devices must use 10% capacitors. The EV kit software supports either 10% or 20% capacitor tolerance.

Controlling the Devices

Select which chip to work with by picking it from the address assignment grid, or by dropping down the CEXT capacitor combo box.

Set the command word drop-down combo boxes (SYNCIO, Input A/B, Filtered/Unfiltered, etc.). To write to a single device, click the Write button. To write to all devices, click the Broadcast button. To read back the device configuration, click the Read button. Read-back data appears underneath the combo boxes. The SYNCIO bit is only active on the MAX7428.

Detailed Description of Hardware

Master/Slave Synchronization

One MAX7428 can control the clamping on another MAX7428. First, assign unique chip addresses by clicking Initialize MAX7428EVKIT. Next, set the configuration word to "SYNCIO in" and click Broadcast. Finally, select the device that will be the master, and write configuration word with "SYNCIO out", and connect the sync signals together. This application is demonstrated on the MAX7428EVKIT. This configuration is typically used for Y-C or Y-Pb-Pr systems. It allows the sync information on Y (luma) to be sent to the other channels.

MAX7432 Evaluation Kit

Evaluates: MAX7428/MAX7430/MAX7432

Table 1. Jumper Functions

JUMPER	POSITION	FUNCTION
JU1	Closed*	U1, U2, U3 are powered by 5V from the 68HC16 module
JU1	Open	U1, U2, U3 require external 5V power source applied at terminal block TB1

*Default configuration

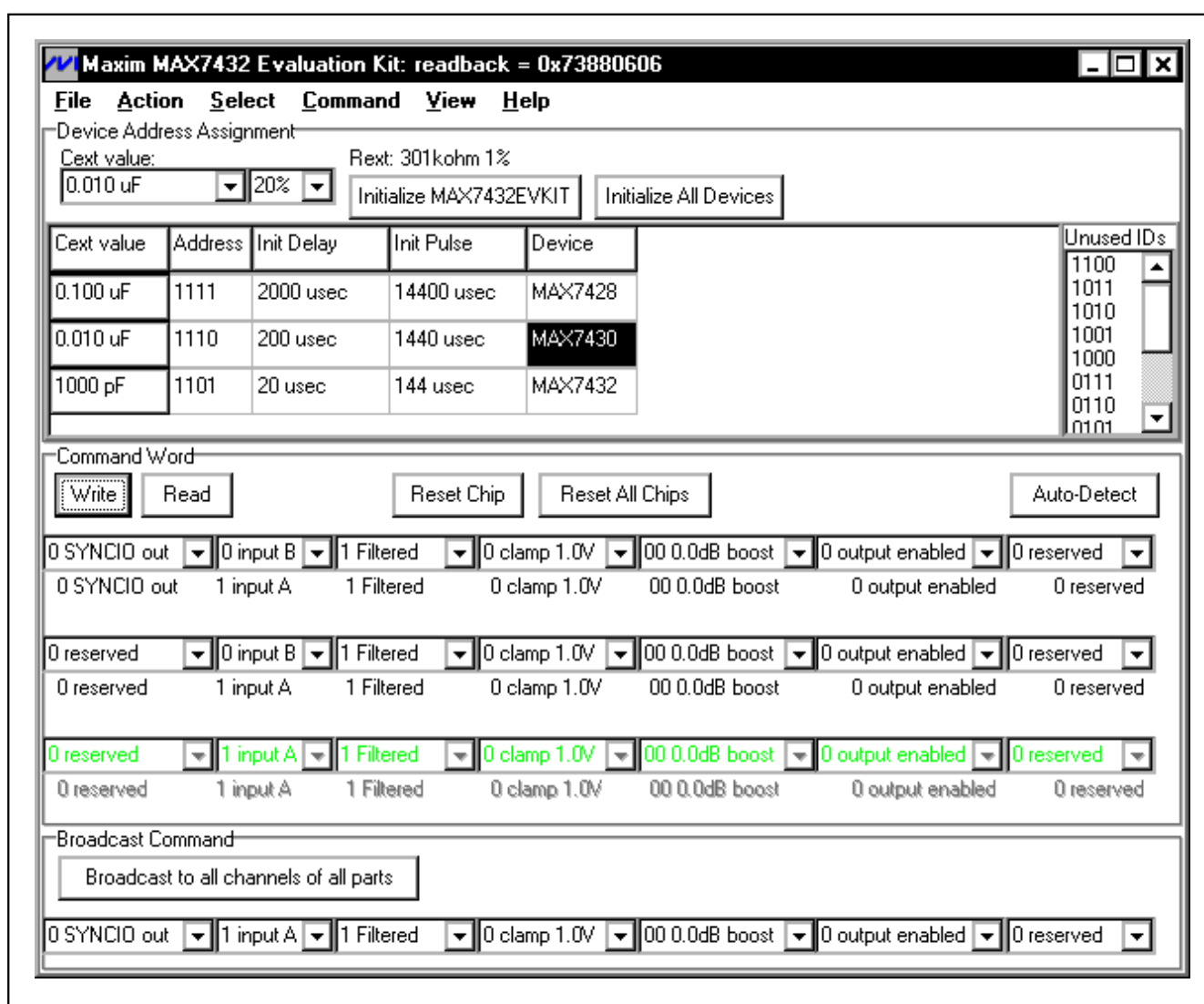

Figure 1. MAX7432 EV Kit Software

MAX7432 Evaluation Kit

Evaluates: MAX7428/MAX7430/MAX7432

```
; Maxim Single Pin Bus Protocol used on MAX7432 (Excerpt)
; Complete source code is included on MAX7432 EVKIT disk.
;
; High-level GUI program sends commands to the MSPB code.
; On Entry:   register Z points to null-terminated command string.
; On Exit:   _readback contains the value read by the (R) bits.
CmdWLoop:
    ldaa 0,z
    aiz #1
    cmpa #0
    beq CmdWDone
    ; Readback timing:
    ; From rising edge of prompt (0) to bus release: 1.0 us min, 2.3 us max
    ; Data valid window: 2.3 us to 4.7 us after rising edge of prompt
    ; From rising edge of prompt to bus assert: 4.7 us min, 13 us max
    cmpa #'R'
    bne CmdWNotR
    BCLR PDDR,#BitBangPin ; make data an input...
    ldaa GTPPDR
    BCLR GTPPDR,#DebugReadPin ; debug strobe
    ; shift msb into carry
    aslw _readback+2,y
    rolw _readback,y ; rotate carry into lsb
    anda #BitBangPin ; drive I/O high
    cmpa #0
    beq CmdWRskip
    inc _readback+3,y
CmdWRskip:
    BSET GTPPDR,#DebugReadPin ; debug strobe
    BSET GTPPDR,#BitBangPin ; drive I/O high
    BSET PDDR,#BitBangPin ; make sure data is an output
    bra CmdWLoop ; jump back to loop, process next character
CmdWNotR:
    cmpa #'0'
    bne CmdWNot0
    ldd #DoZeroTimingValue
    jsr DoPulse_D
    bra CmdWLoop ; jump back to loop, process next character
CmdWNot0:
    cmpa #'1'
    bne CmdWNot1
    ldd #DoOneTimingValue
    jsr DoPulse_D
    bra CmdWLoop ; jump back to loop, process next character
CmdWNot1:
    cmpa #'2'
    bne CmdWNot2
    ldd #DoWPTimingValue
    jsr DoPulse_D
    bra CmdWLoop ; jump back to loop, process next character
CmdWNot2:
    cmpa #'A'
    bne CmdWNotA
    jsr EXECUTE_DELAY_A
    bra CmdWLoop ; jump back to loop, process next character
CmdWNotA:
    cmpa #'B'
    bne CmdWNotB
    jsr EXECUTE_DELAY_B
    bra CmdWLoop ; jump back to loop, process next character
CmdWNotB:
    cmpa #'H'
    bne CmdWNotH
    ; delay for 5 usec
    ldd #DoWH5usecTimingValue
    jsr DoPulseDly
    bra CmdWLoop ; jump back to loop, process next character
CmdWNotH:
    bra CmdWLoop ; jump back to loop, process next character
CmdWDone:
    rts
```

Listing 1. Simplified Interface

MAX7432 Evaluation Kit

Evaluates: MAX7428/MAX7430/MAX7432

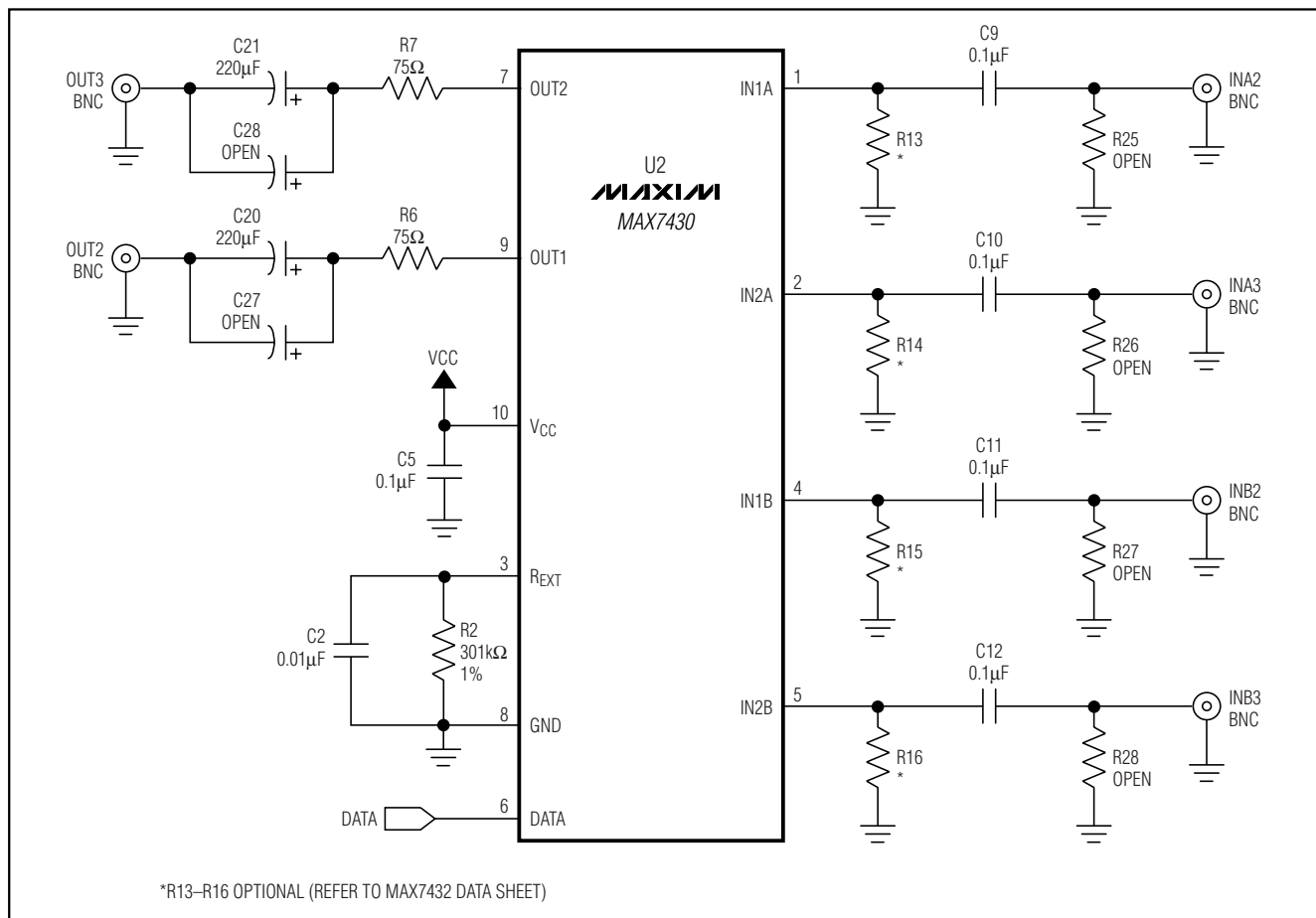

Figure 2a. MAX7432 EV Kit Schematic

MAX7432 Evaluation Kit

Evaluates: MAX7428/MAX7430/MAX7432

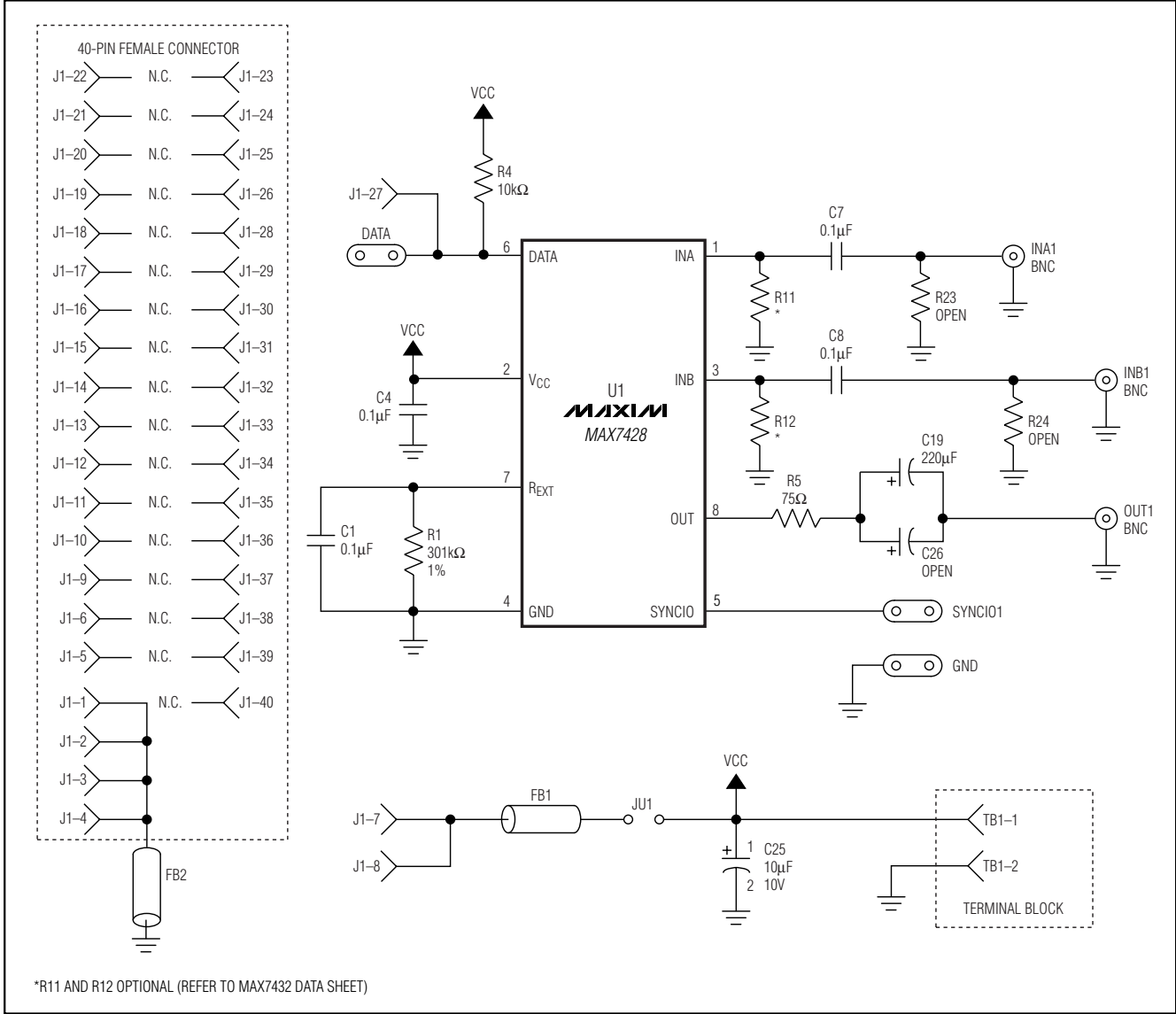

Figure 2b. MAX7432 EV Kit Schematic

MAX7432 Evaluation Kit

Evaluates: MAX7428/MAX7430/MAX7432

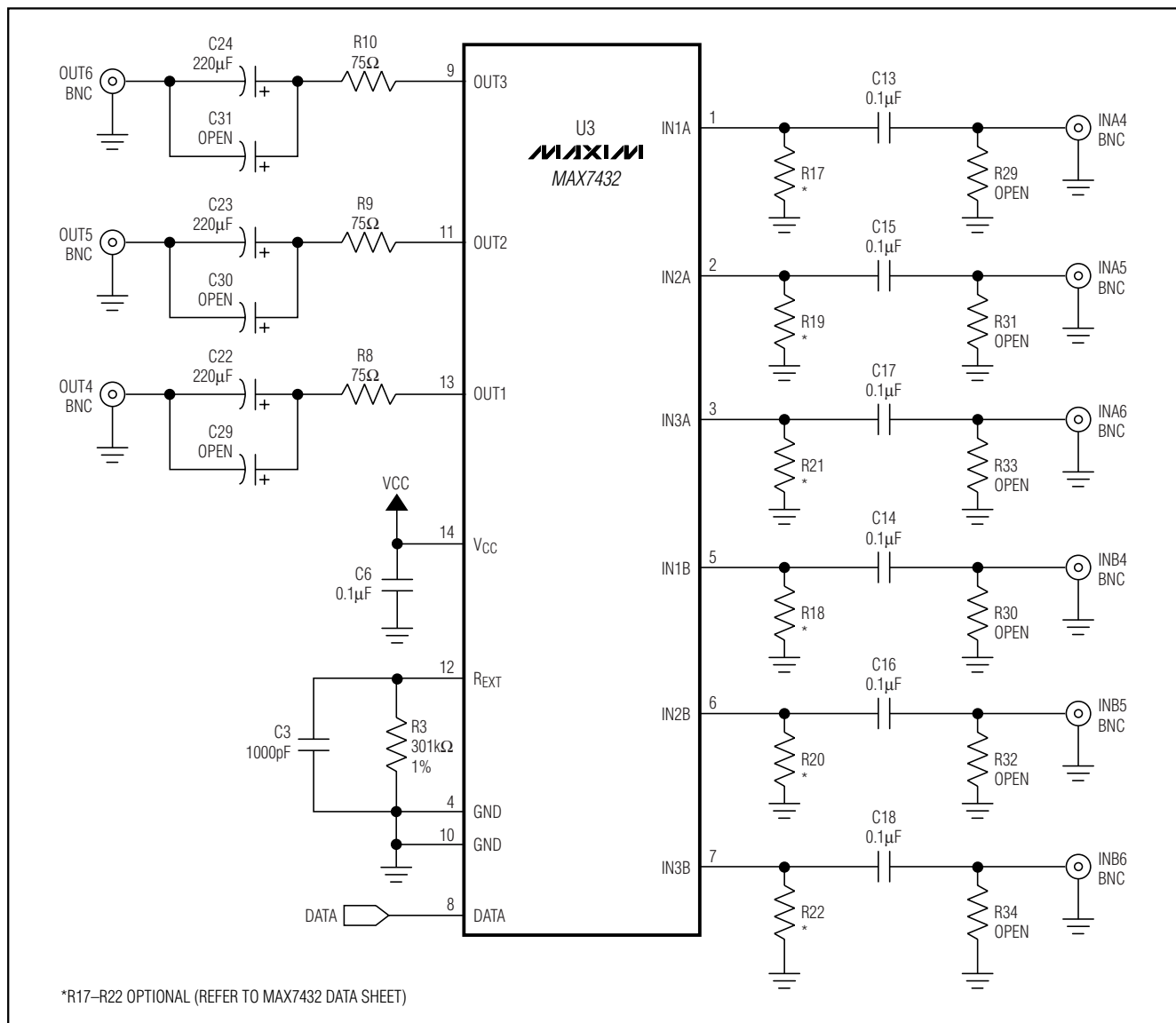

Figure 2c. MAX7432 EV Kit Schematic

MAX7432 Evaluation Kit

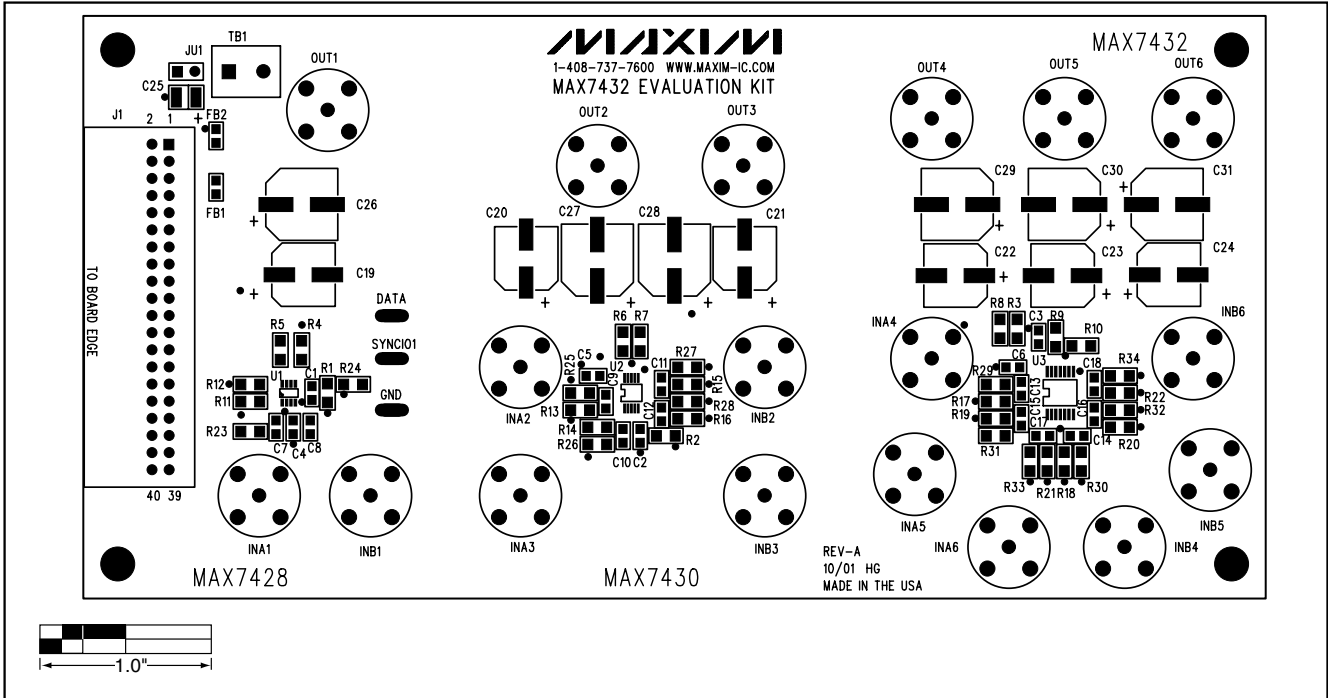

Figure 3. MAX7432 EV Kit Component Placement Guide—Component Side

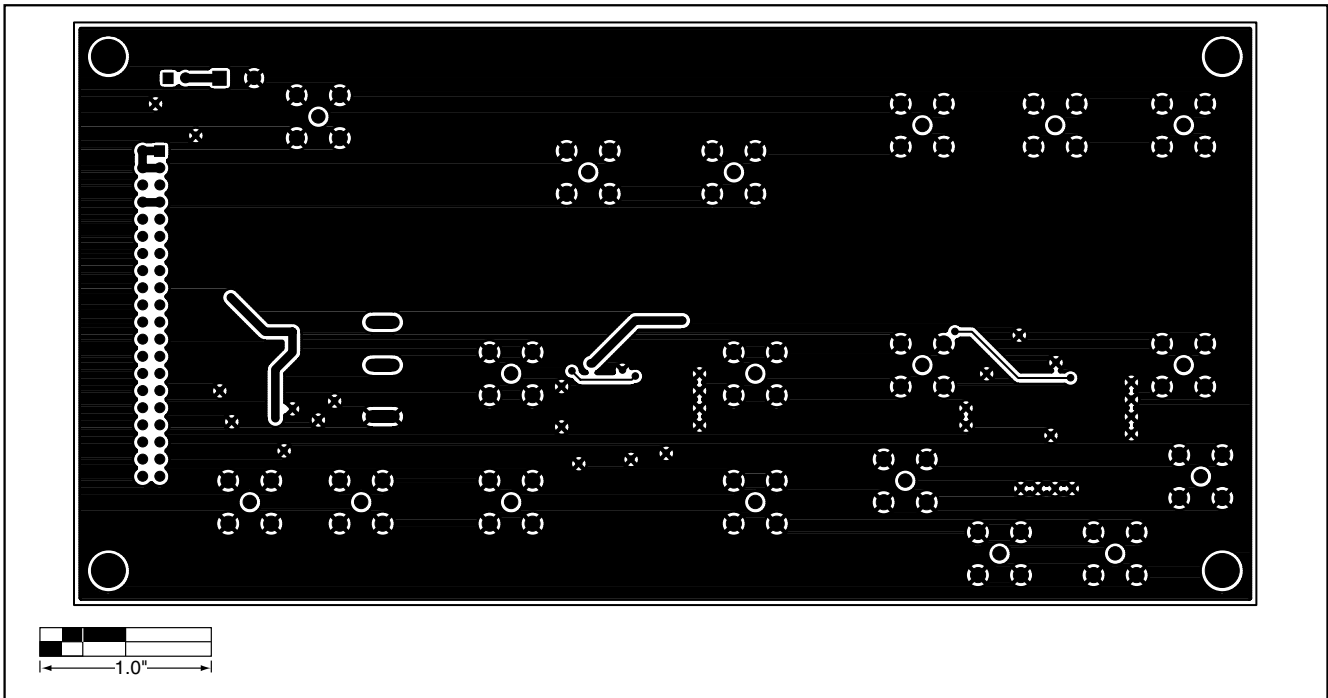

Figure 4. MAX7432 EV Kit PC Board Layout—Solder Side

MAX7432 Evaluation Kit

Evaluates: MAX7428/MAX7430/MAX7432

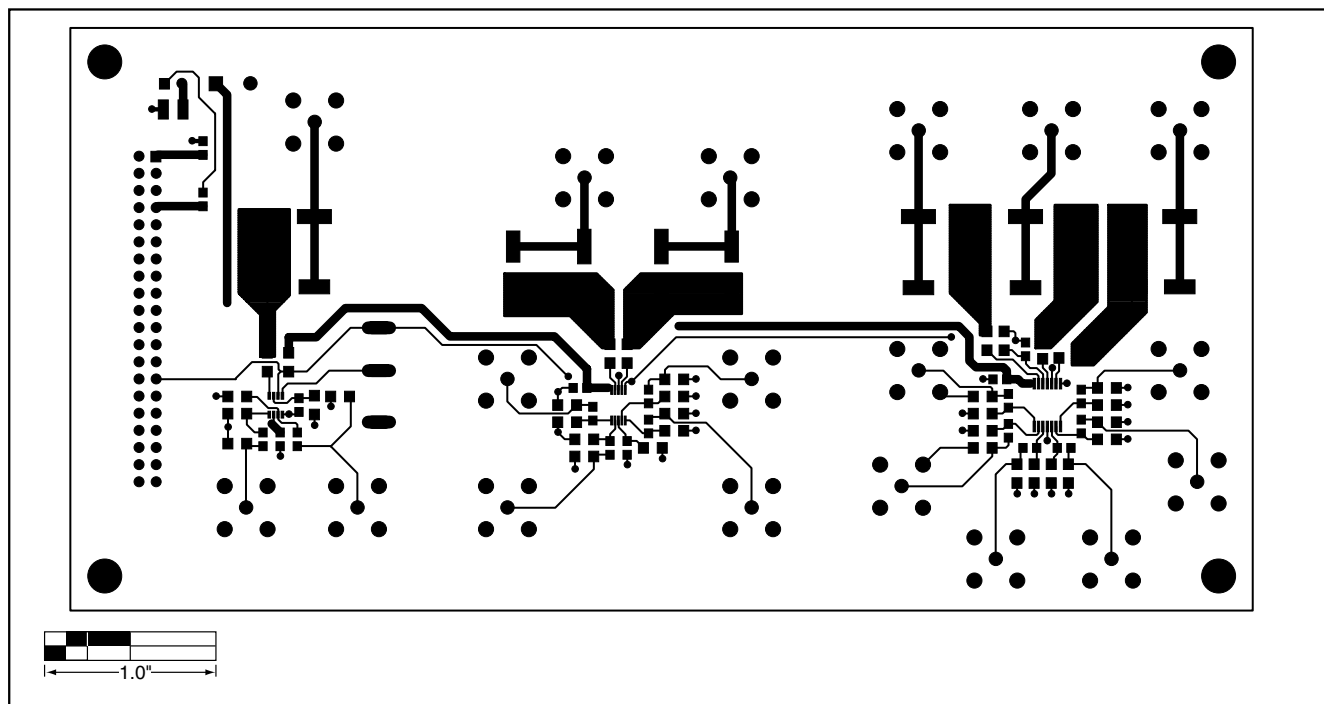

Figure 5. MAX7432 EV Kit PC Board Layout—Component Side

Maxim cannot assume responsibility for use of any circuitry other than circuitry entirely embodied in a Maxim product. No circuit patent licenses are implied. Maxim reserves the right to change the circuitry and specifications without notice at any time.

Maxim Integrated Products, 120 San Gabriel Drive, Sunnyvale, CA 94086 408-737-7600 _____ 9